

# Yanmar type 4JH5E

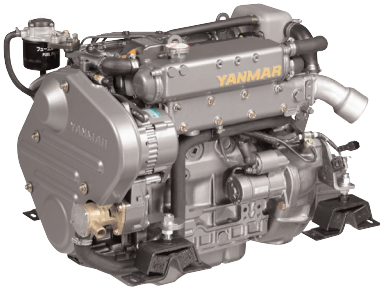

<b>Configuration</b>	4-stroke, vertical, water cooled diesel engine
<b>Maximum output at crankshaft</b>	* 39.6 kW (53,1 mhp) / 3000 rpm
<b>Continuous rating output at crankshaft</b>	36.0 kW (48,3 mhp) / 2907 rpm
<b>Displacement</b>	2.19 L (134 cu in)
<b>Bore x stroke</b>	88 mm x 90 mm (3.46 in x 3.54 in)
<b>Cylinders</b>	4 in line
<b>Combustion system</b>	Direct injection
<b>Aspiration</b>	Natural aspiration
<b>Starting system</b>	Electric starting 12 V
<b>Alternator</b>	12 V - 80 A
<b>Cooling system</b>	Fresh water cooling by centrifugal water pump and rubber impeller sea water pump
<b>Lubrication system</b>	Enclosed, forced lubricating system
<b>Direction of rotation (crankshaft)</b>	Counter clockwise viewed from flywheel side
<b>Dry weight without gear</b>	201 kg (443 lbs)
<b>Environmental</b>	EU: RCD / US: EPA Tier 3
<b>Engine mounting</b>	Rubber type flexible mounts

NOTE: Fuel condition: Density at 15°C = 0.84 g/cm<sup>3</sup>  
 Fuel temperature 40°C at the inlet of the fuel injection pump (ISO 8665:2006)

**Dimensions** (For detailed line-drawings, please refer to our web-site: [www.yanmarmarine.com](http://www.yanmarmarine.com) or contact your supplier)

**Rear view**

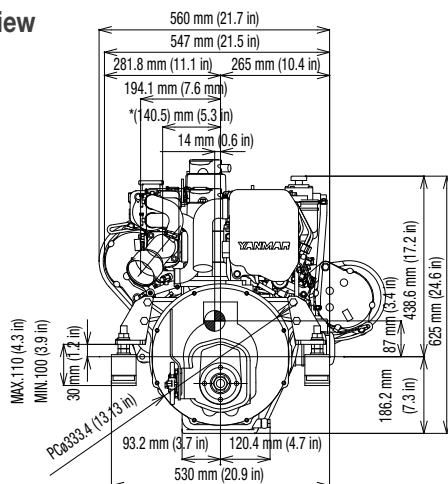

**Right side view**

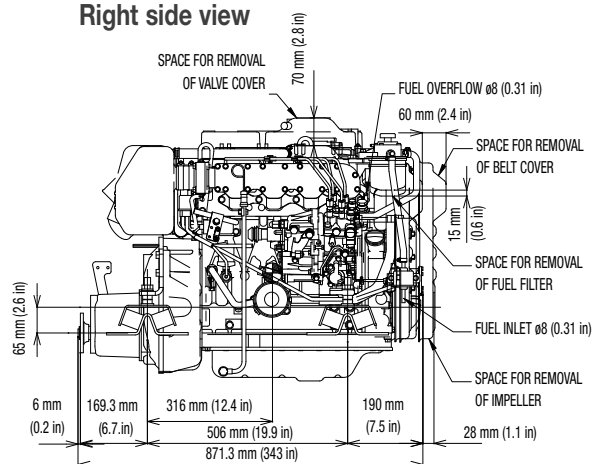

4JH5E with KM35P marine gear

## Performance Curves (Output is according ISO 8665)

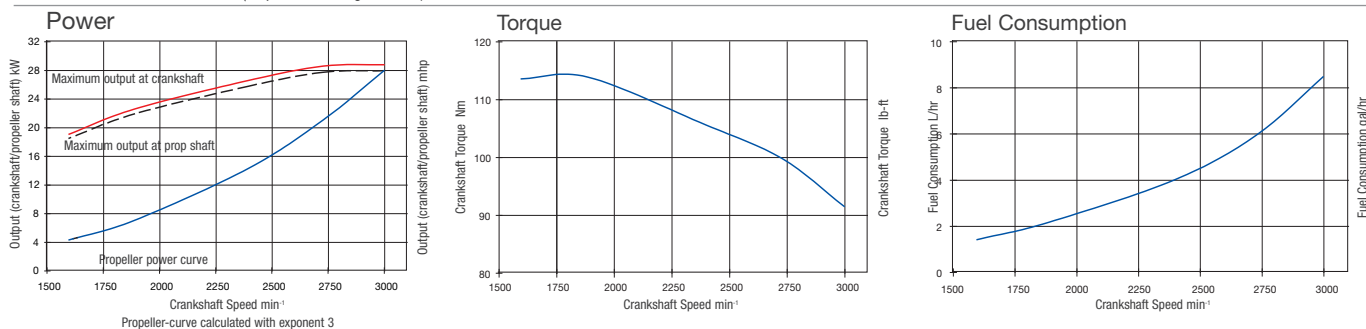

## Marine Gears/Drive

Model	KM35P		KM35A2 (down angle: 7deg)		KM4A1 (down angle: 7deg)			ZF30M		Saildrive SD50
Type	Mechanical cone clutch		Mechanical cone clutch		Mechanical cone clutch			Mechanical multy disc		Mechanical cone clutch
Dry weight	12 kg (27 lbs)		13 kg (29 lbs)		29 kg (64 lbs)			28 kg (61 lbs)		40 kg (88 lbs)
Reduction ratio (fwd/asn)	2.36/3.16	2.61/3.16	2.33/3.06	2.64/3.06	1.47/1.47	2.14/2.14	2.63/2.63	2.15/2.64	2.70/2.64	2.32/2.32
Propeller speed(fwd/asn)	1271/949	1149/949	1288/980	1136/980	2041/2041	1402/1402	1141/1141	1395/1136	1111/1136	1293/1293
Direction of rotation (propeller shaft - fwd)	Clockwise viewed from stern		Clockwise viewed from stern		Clockwise viewed from stern			Clockwise viewed from stern		Clockwise & counter clockwise viewed from stern
Dry weight engine and gear/drive	213 kg (469.5 lbs)		214 kg (471.7 lbs)		214 kg (471.7 lbs)			229 kg (505 lbs)		241 kg (531 lbs)
Length engine and gear/drive	871 mm (34.3 in)		864 mm (34.0 in)		922 mm (36.3 in)			950 mm (37.4 in)		1067 mm (42.0 in)

## Instrument Panels

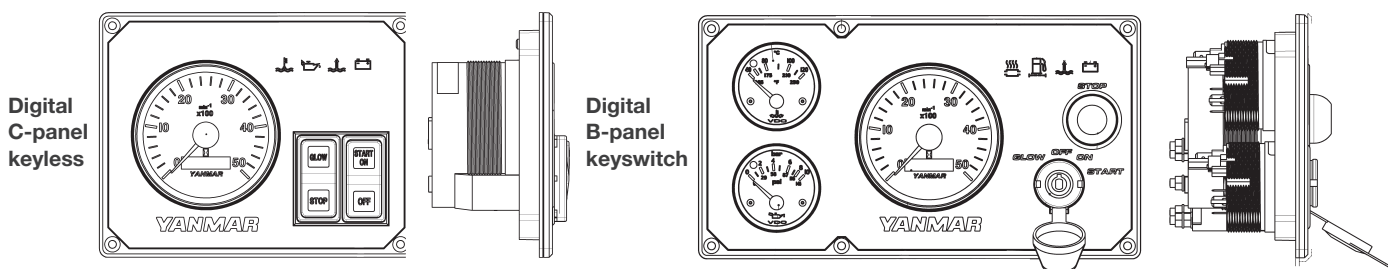

### Digital B-panel and C-panel with keyswitch

Keyswitch  
 Stop Button  
 Tachometer with hour  
 Indication (display)  
 Audible alarm  
 Alarm lights  
 Battery low charge  
 Coolant High temperature  
 Lubricating oil low pressure  
 Water in saildrive seal

### Digital B-panel and C-panel keyless

Sealed rocker switch for engine on/start  
 Sealed rocker switch for glow function  
 Tachometer with hour  
 Indication (display)  
 Audible alarm  
 Alarm lights  
 Battery low charge  
 Coolant High temperature  
 Lubricating oil low pressure  
 Water in saildrive seal

Extra for all C-panels: Coolant temperature gauge, Lubricating oil pressure gauge

## Accessories

### Standard Features

- Digital B-panel with keyswitch
- 4 M wiring harness
- Operation manual
- Set of flexible engine mounts
- Exhaust mixing elbow (L-type)
- V-belt safety cover
- Fresh water expansion tank
- Alternator 12 V - 80 A
- Electric stop solenoid

### Optional

- Digital B panel keyless
- Digital C panel with key switch or key less
- Second Alternator 12V80A, 12V130A or 24V75A
- High riser mixing Elbow
- 6M, 10M Extension Wire harness
- Hot water kit, with or without cocks
- Second station harness